

# nannidiesel

energy in blue

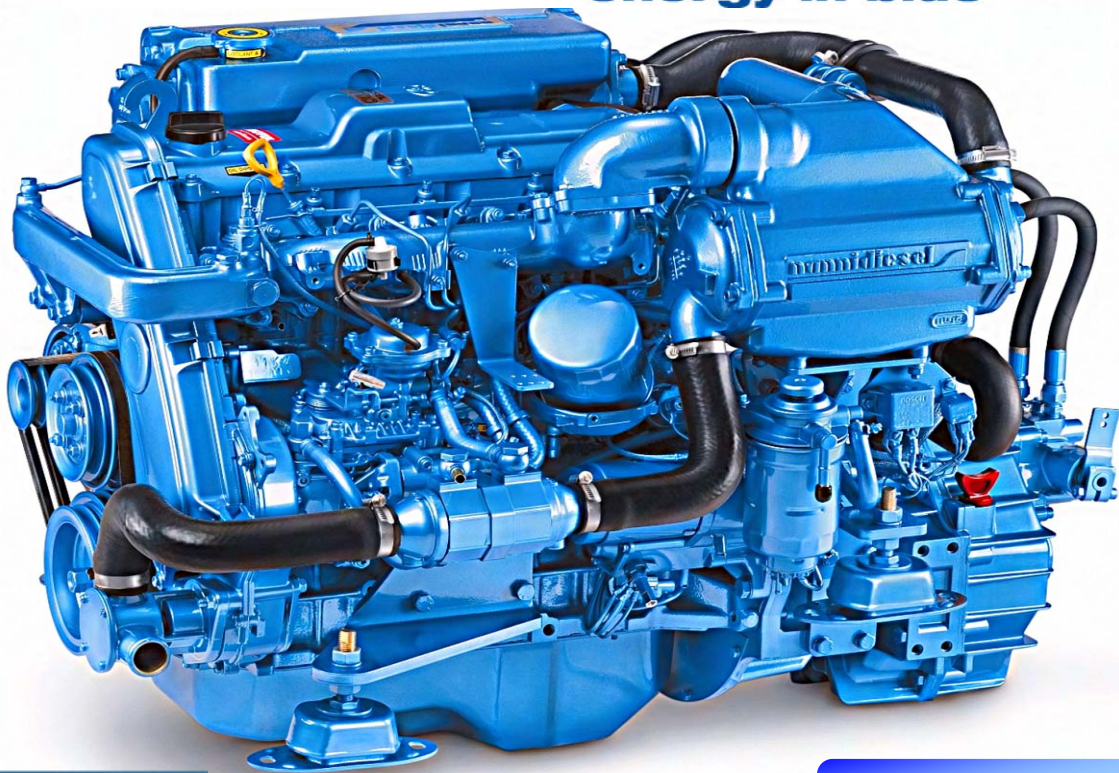

**4.380 TDI**

**128,8 kW (175 hp)**

## Technical Specifications

Power	<b>128,8 kW ( 175 hp )</b>
Maximum RPM	<b>3600 rpm</b>
Displacement	<b>181.94 ci (2982 cc)</b>
N° of cylinders	<b>4 in line</b>
Bore / Stroke	<b>3.78x4.05" (96x103 mm)</b>
Compression Ratio	<b>19,7 / 1</b>
Injection	<b>Indirect</b>
Intake	<b>Turbo intercooler</b>
Cooling System	<b>Heath Exchanger</b>
Alternator	<b>12 V 80 A</b>
Instrument Panel	<b>C 3 luxe</b>
Transmission	<b>Hydraulical</b>
Weight (incl trans)	<b>761.2 lb (346 kg)</b>

## Hose Diameters

Exhaust	<b>3.50" (90 mm)</b>
Fuel	<b>0.40" (10 mm)</b>
Sea Water	<b>1.50" (38 mm)</b>
Engine Max Install. Angle	<b>15°</b>

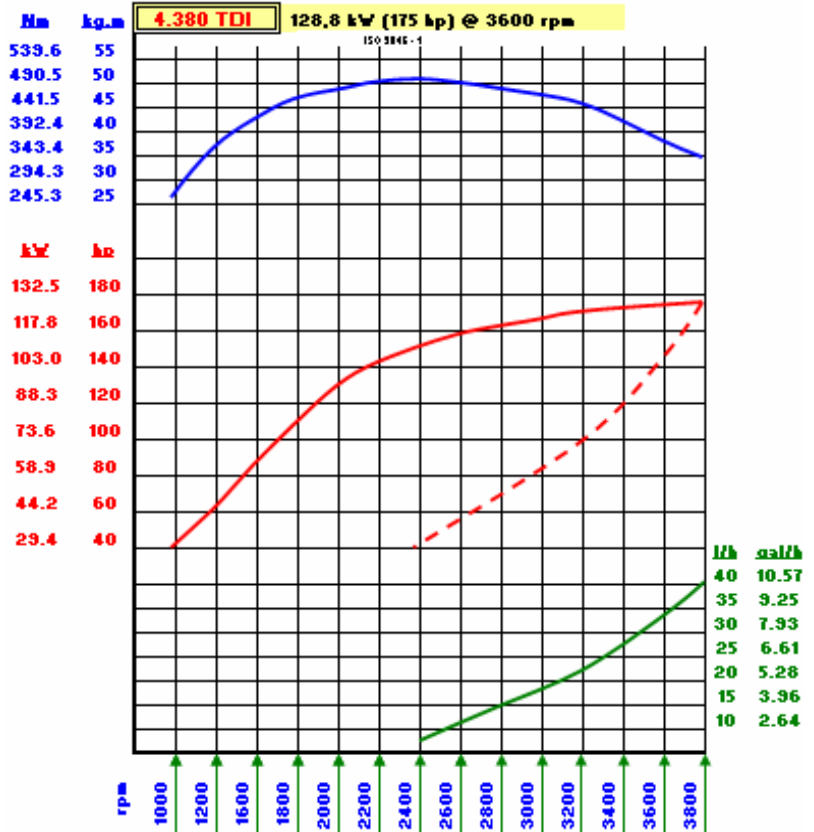

NANNI DIESEL recommends



**4.380 TDI**

**Kubota BASE**

## Line drawings

4.380 TDI / ZF 45A

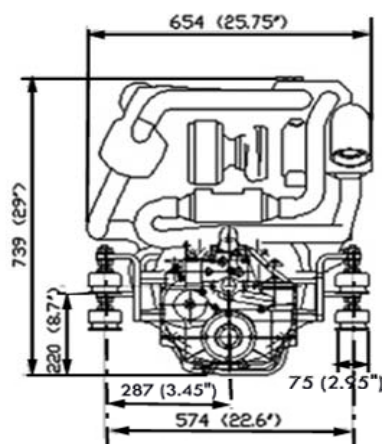
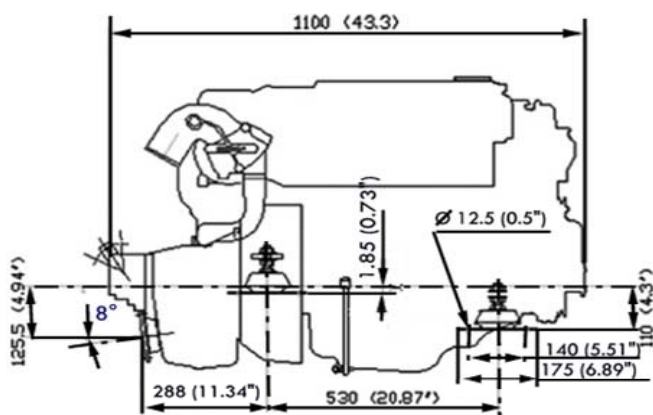

## Standard Equipment

- C 3 lux Instrument Panel
  - \_ Tachometer / hourmeter
  - \_ Oil Pressure Warning Light & Audio Alarm
  - \_ Water T° Warning Light & Audio Alarm
  - \_ Battery Charge
  - \_ Glow Plugs
  - \_ Water temperature indicator
  - \_ Battery charge indicator
  - \_ Oil pressure indicator
  - \_ Starter Key
- Hydraulical Transmission
- Prearrangemt for cable use
- Engine Mounts
- Owners Manual
- Warranty Certificate



(270 x 188 mm)  
10 ± 7.4"

- Electrical Harness 13' (4m)
- Heath Exchanger
- Fresh Water Pump
- Thermostat
- Sea Water Pump
- Fresh Water Cooled Exhaust Manifold
- Exhaust Manifold With Water Injection
- Turbo Compressor
- In Line Injection Pump
- Fuel Pump
- Fuel Filter
- Oil Filter
- Extraction Oil Pump
- Electrical Wiring 12 V
- Electrical Stop

## Optional

- Bipolar Electrical Wiring
- Coupling
- Propeller shaft
- Exhaust System
- Remote Control
- Sea Water Hoses
- Fuel Hoses
- Sea Water Filter
- Angled or V transmission
- Additional alternators
- Flying Bridge instrument Panel
- Trolling valve



Riverside Estate,  
Brundall, Norwich, NR13 5PL

Tel: 01603 714077

Fax: 01603 712211

e-mail: [sales@peachment.co.uk](mailto:sales@peachment.co.uk)